

# GROVE<sup>®</sup> TM1300

**130 TON CAPACITY  
(120 MT)  
TRUCK MOUNTED  
HYDRAULIC CRANE**

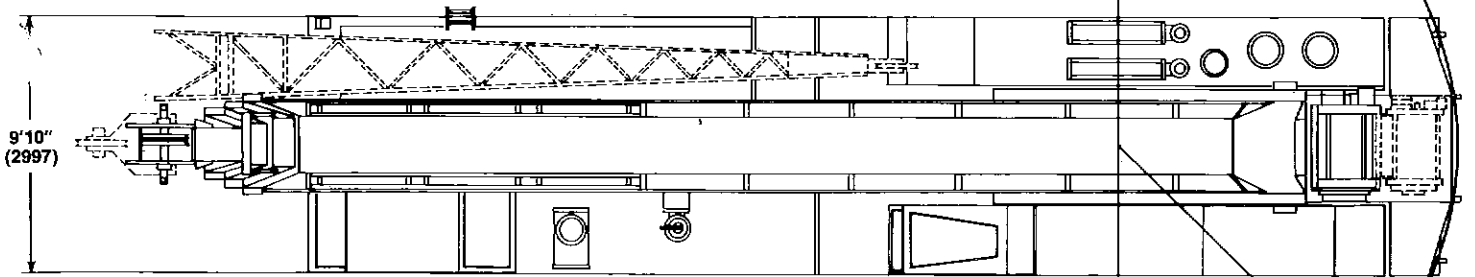



TURNING RADIUS 51' (15 545)

GROUND CLEARANCE 10-1/4" (with float removed) (260)  
 TAILSWING 13'-3/4" (counterweight in travel position) (4005)  
 TAILSWING 16'-1/4" (counterweight in working position) (4910)  
 NOTE: Dimensions shown in parentheses are millimeters (mm)

## DIMENSIONS

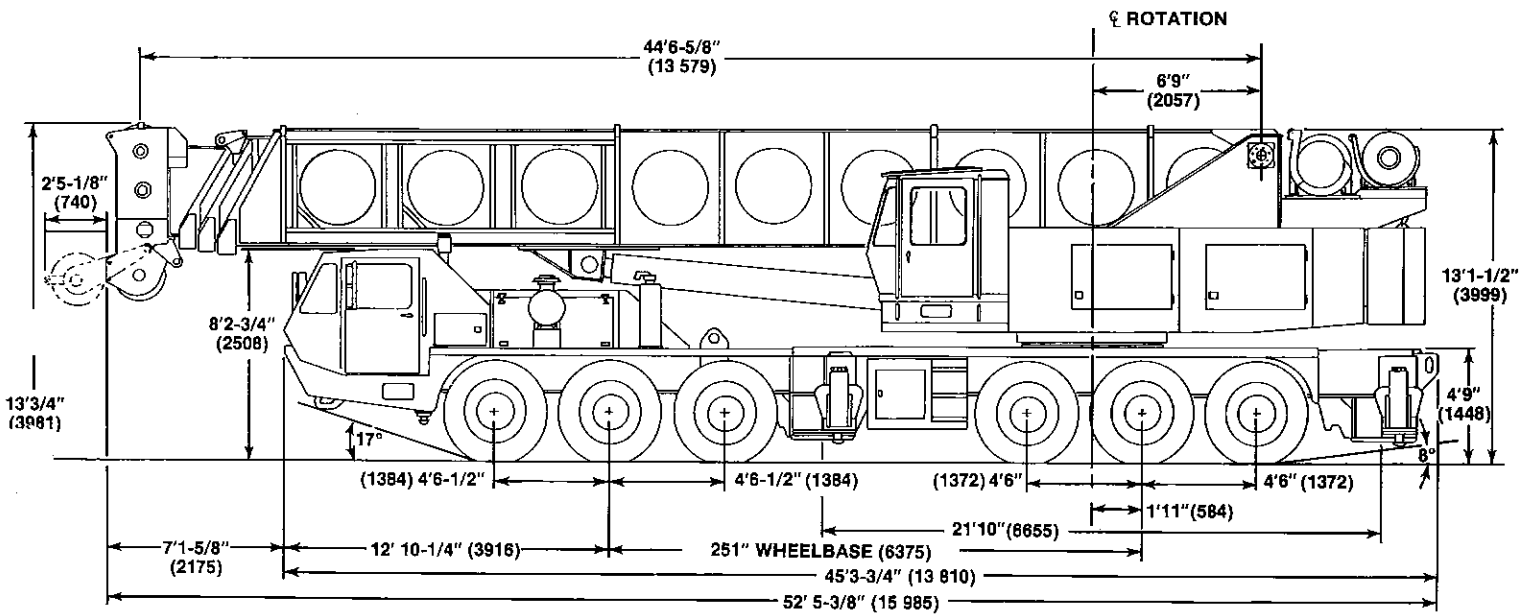
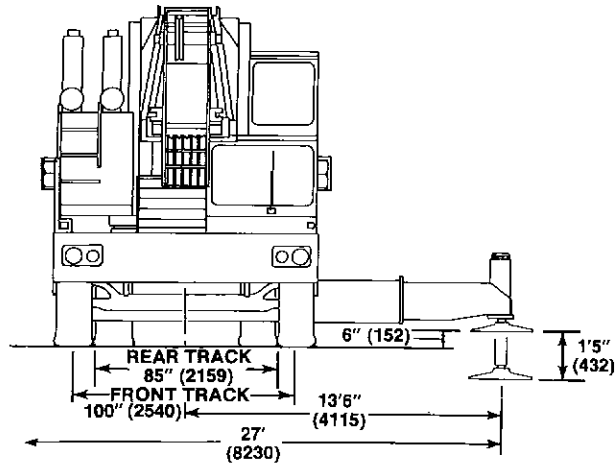

# HOIST SPECIFICATIONS

**DESCRIPTION:** Two speed and pull, planetary drive, power up and down with integral automatic brake and electronic hoist drum rotation indicator.

**DESCRIPTION:** Series parallel circuitry and two motors provide both high line pull and speed ranges, up and down, equal speed, planetary reduction with integral automatic brake and electronic hoist drum rotation indicator.

HOIST DATA	MAIN HOIST GEARMATIC MODEL 44		*AUXILIARY HOIST GROVE MODEL HO30B-26	
	<b>DRUM DIMENSIONS</b>	20 in. dia. (508mm) 26 in. length (660mm) 30 in. flange dia. (762mm)		16 in. dia. (406mm) 26 in. length (660mm) 24 in. flange dia. (610mm)
<b>PERFORMANCE:</b>				
<b>MAX. SINGLE LINE SPEED:</b>	Hi-Speed Range	Lo-Speed Range	Hi-Speed Range	Lo-Speed Range
<b>BARE DRUM</b>	282 FPM (86 m/min)	141 FPM (43 m/min)	435 FPM (133 m/min)	215 FPM (66 m/min)
<b>MEAN DRUM</b>	330 FPM (101 m/min)	165 FPM (50 m/min)	525 FPM (160 m/min)	265 FPM (81 m/min)
<b>FULL DRUM</b>	376 FPM (115 m/min)	188 FPM (57 m/min)	595 FPM (181 m/min)	295 FPM (90 m/min)
<b>MAX. SINGLE LINE PULL</b>				
<b>BARE DRUM</b>	14,000 lbs. (6350 kg)	28,000 lbs. (12700 kg)	8,400 lbs. (3810 kg)	16,800 lbs. (7620 kg)
<b>MEAN DRUM</b>	11,772 lbs. (5340 kg)	23,544 lbs. (10680 kg)	6,945 lbs. (3150 kg)	13,890 lbs. (6300 kg)
<b>FULL DRUM</b>	10,312 lbs. (4678 kg)	20,624 lbs. (9355 kg)	6,125 lbs. (2778 kg)	12,245 lbs. (5554 kg)
<b>DRUM ROPE CAPACITY</b>				
<b>+MAX. STORAGE</b>	1,010 ft. of 1 in. dia. rope (308m of 25.4mm)		1,060 ft. of 3/4 in. dia. rope (323m of 19mm)	
<b>++MAX. USABLE</b>	820 ft. of 1 in. dia. rope (250m of 25.4mm)		855 ft. of 3/4 in. dia. rope (261m of 19mm)	
<b>PERMISSIBLE SINGLE LINE ROPE PULL W/ 5:1 SAFETY FACTOR</b>	1 in. (25mm) 18x19 class 20,400 lbs. (9253 kg)		3/4 in. (19mm) 18x19 class 11,500 lbs. (5216 kg)	

**NOTES:** \*Denotes Optional Equipment.

+6th layer of rope not recommended for hoisting operations.

++With wire rope minimum 1/2 in. (13mm) below top of drum flange.

The Gearmatic model 44 hoist with controlled free fall is available as the optional main hoist with the same specifications as shown.

# SPEED AND GRADEABILITY

ENGINE	SPEED RANGES @ MAX. GOVERNED RPM		% OF GRADEABILITY @ MAX. TORQUE	
	Aux. Low	Aux. Direct	Aux. Low	Aux. Direct
GM8V-71TA			46.2 to 2.3%	21.9 to .34%
Cummins NTC350	1.6 to 20.6 MPH (2.6 to 33 km/h)	3.3 to 41.8 MPH (5.3 to 67.3 km/h)	53.9 to 2.9%	25.6 to .63%
Caterpillar 3406TA			48.8 to 2.5%	23.2 to .44%

**NOTE:** Performance data based on 167,000 lbs. (75,751 kg) GVW and standard SAE engine rating conditions using standard tires, transmission, engine, and axles. Performance data may vary plus or minus 10% due to variations in engine performance and vehicle weights. Machines should be operated within the limits of crank case design (15°). Gradeability values above 45% are theoretical.

## ENGINE SPECIFICATIONS SUPERSTRUCTURE

MAKE & MODEL	Detroit 8.2L Turbo	*Cummins V555	*Caterpillar 3208
TYPE	8 cyl. OHV, diesel	8 cyl. OHV, diesel	8 cyl. OHV, diesel
COMBUSTION	4 cycle, turbocharged	4 cycle, naturally aspirated	4 cycle, naturally aspirated
BORE & STROKE	4.25" x 4.41" (108 x 112mm)	4.625" x 4.125" (117 x 105mm)	4.5" x 5.0" (114 x 127mm)
DISPLACEMENT	500 cu. in. (8195 cm <sup>3</sup> )	555 cu. in. (9096 cm <sup>3</sup> )	636 cu. in. (10424 cm <sup>3</sup> )
HORSEPOWER (GROSS/NET)	205/163 @ 3000 RPM (153/122 KW)	215/196 @ 3000 RPM (160/146 KW)	210/199 @ 2800 RPM (157/148 KW)
TORQUE (NET)	383 ft. lb. @ 1700 RPM (53 kg/m)	394 ft. lb. @ 1800 RPM (54 kg/m)	446 ft. lb. @ 1400 RPM (62 kg/m)
COOLING SYSTEM	Liquid	Liquid	Liquid
ALTERNATOR	90 AMP, 12 volt	90 AMP, 12 volt	90 AMP, 12 volt
BATTERY	(2) 625 CCA @ 0°F	(4) 475 CCA @ 0°F	(4) 475 CCA @ 0°F
AIR CLEANER	2 stage, dry type	2 stage, dry type	2 stage, dry type
ELECTRICAL/STARTING SYSTEM	12/24 volt, negative ground	12/24 volt, negative ground	12/24 volt, negative ground
FUEL TANK	(1) 60 gal. (227 liter)	(1) 60 gal. (227 liter)	(1) 60 gal. (227 liter)

## CARRIER

MAKE AND MODEL	GM 8V-71TA	*Cummins NTC350
TYPE	8 cyl. OHV, diesel	6 cyl. OHV, diesel
COMBUSTION	2 cycle, turbocharged	4 cycle, turbocharged
BORE & STROKE	4.25" x 5" (108 x 127mm)	5.5" x 6" (140 x 152mm)
DISPLACEMENT	568 cu. in. (9310 cm <sup>3</sup> )	855 cu. in. (14013 cm <sup>3</sup> )
HORSEPOWER (GROSS/NET)	370/335 @ 2100 RPM (276/250 KW)	350/304 @ 2100 RPM (261/227 KW)
TORQUE (NET)	870 ft. lb. @ 1600 RPM (120 kg/m)	903 ft. lb. @ 1500 RPM (125 kg/m)
COOLING SYSTEM	Liquid	Liquid
ALTERNATOR	90 AMP, 12 volt	90 AMP, 12 volt
BATTERY	(4) 475 CCA @ 0°F	(4) 475 CCA @ 0°F
AIR COMPRESSOR	24 CFM (680 liter/min)	30 CFM (850 liter/min)
AIR CLEANER	Single stage, dry type	Single stage, dry type
ELECTRICAL/STARTING SYSTEM	12/24 volt, negative ground	12/24 volt, negative ground
FUEL TANK	(1) 100 gal. (379 liter)	(1) 100 gal. (379 liter)

CCA = Cold cranking amperage per battery

\*Denotes optional equipment

Note: GM and Cummins engines equipped with Jacobs engine brake.

# TM1300

## CARRIER SPECIFICATIONS

**FRAME** - High-strength steel, all-welded construction of box-type design with integral welded outrigger boxes.

**OUTRIGGERS** - Hydraulic double box 2-stage telescoping beam outriggers, integral welded boxes, removable beams, vertical jack cylinders with integral holding valves and 30-1/2 in. (775mm) diameter steel floats. Beams extend to 27 ft. (8230mm) centerline to centerline and retract to 9 ft. 10 in. (3.0m) overall width. Positive mechanical spin locks on each vertical jack to secure outriggers at any level. Controls and sight leveling bubble located in superstructure cab and each side of carrier frame. Powered by superstructure engine.

**FRONT END STABILIZER** - A fifth hydraulic vertical outrigger jack cylinder with integral holding valve is mounted to the front frame section of the chassis to permit 360° lifting capabilities. 24 in. (610mm) diameter steel float easily removed for highway travel. Individual controls for fifth outrigger cylinder conveniently located in superstructure cab and each side of carrier frame.

**CAB** - Two-man low profile design, all steel with acoustical treatment, tinted tempered safety glass, (front windshield is tinted laminated); windshield washer and electric wiper, door and window locks. Bos-trom "T" bar driver's seat and Bos-trom companion seat, seat belts, heater, (air conditioning available), defroster fan, dual West Coast mirrors, domelight, dashlight, electric horn, traffic hazard warning switch (four-way flasher), complete instrumentation and driving controls, sliding right side and roll-down left side glass for ventilation;

2-3/4 lb. (1.25 kg) dry type fire extinguisher.

**CAB INSTRUMENTATION** - Engine oil pressure gauge, speedometer, air pressure gauge, fuel level gauge, engine water temperature gauge, voltmeter, tachometer, low air pressure audio-visual warning device, high beam indicator, ignition-on indicator lamp.

**STEERING GEAR** - Ross cam and lever type with Garrison hydraulic power assist.

**CLUTCH** - Lipe Rollway 14 in. (356mm) two plate dry disc.

**TRANSMISSION** - Fuller Road-ranger (RT 11609A) 9-speeds forward, 2 reverse, with Fuller AT1202 2-speed auxiliary.

**UNIVERSAL JOINTS** - Needle bearing type.

**AXLES** - Front: (3) Rockwell tubular steering FL 951, 100 in. (2540mm) track.

Rear: (3) Rockwell EPRG 1356 planetary drive with interaxle differential; 85 in. (2159mm) track.

**SUSPENSION** - Front: Reyco 21B spring-mounted tridem.

Rear: Hendrickson tri-axle equalizing beam with solid steel saddles.

**FUEL TANK** - Single 100 gal. (379 liters) capacity mounted on right side of frame.

**TIRES** - Michelin 14:00x20-22 ply rated (G-20X) radial tube-type, front and rear.

**TIRE INFLATION KIT** - Quick connect air outlet located at midpoint on either side of carrier. Includes dual foot air chuck and 25 ft. (7.6m) coiled nylon tubing.

**WHEELS** - Steel spoke 10 in. x 20 in. (254mm x 508mm).

**BRAKES** - Full air on all wheels. Front: 15 in. x 6 in. (381mm x 152mm).

Rear: 16-1/2 in. x 7 in (491mm x 178mm). Total lining area: 2508 sq. in. (16,181 cm<sup>2</sup>). Air dryer provided to minimize moisture accumulation.

**PARKING BRAKE** - Maxi-type, spring set emergency chambers on all rear axles with emergency release kit.

**ELECTRICAL SYSTEM** - 12-volt lighting, 24-volt starting. Lights and reflectors comply with Federal safety standards.

**MISCELLANEOUS STANDARD EQUIPMENT** - Wheel nut wrench and handle, channel type front bumper, two front and rear towing loops, front and rear fenders, ether injection starting aid (less canister), mud flaps, tool storage compartment, front deck hookblock storage trough.

## HYDRAULIC SYSTEM

**RESERVOIR** - 315 gallon (1192 liters), all-steel welded construction with integral baffles, clean-out access and exterior oil sight level gauge.

**FILTER** - Return line type, full flow with by-pass protection and filter by-pass indicator, replaceable cartridge. 25 micron rating.

**CONTROL VALVES** - Six section, gear type driven by superstructure engine. Manual pump disconnect located on lower right side of superstructure. Combined capacity 349 GPM (1321 LPM) @ 2400 RPM.

**OIL COOLER** - Full flow, fin and tube, oil to air.

**POWER DISTRIBUTION** - Auxiliary hoist boost, and inner mid telescope; swing; lift; lift boost, and main hoist boost; outer mid telescope and auxiliary hoist; main hoist.

†Patented Grove feature or patent pending.  
\*Denotes optional equipment.



**ON OUTRIGGERS FULLY EXTENDED - 360°**

Radius in Feet	Main Boom Length in Feet (Power Pinned Fly Retracted)										Power Pin. Fly Ext. & 108 ft.
	45	52	60	68	76	84	92	100	108	140	
10	260,000 (75.5)	157,000 (77.5)	155,000 (80)								
12	232,000 (72.5)	157,000 (75.5)	151,500 (78.5)	136,500 (79.5)	130,000 (80)						
15	185,000 (68)	157,000 (72)	137,000 (75)	122,000 (77)	115,000 (78)	107,000 (79.5)					
20	130,500 (60.5)	130,500 (66)	119,000 (70)	104,000 (72.5)	97,100 (74)	89,650 (76)	82,700 (78)	77,400 (79)	66,800 (80)		
25	99,000 (51.5)	99,000 (59.5)	99,000 (64.5)	91,200 (68)	84,000 (70)	77,100 (72.5)	70,800 (74.5)	66,150 (76)	57,500 (77.5)		
30	78,500 (41.5)	78,500 (52.5)	78,500 (58.5)	78,500 (63)	72,050 (66)	67,600 (68.5)	61,850 (71.5)	57,650 (73)	49,350 (75)	45,000 (79.5)	
35	64,000 (27.5)	64,000 (44.5)	64,000 (52.5)	64,000 (58)	62,500 (61.5)	59,300 (65)	54,800 (68)	51,000 (70)	42,500 (72)	43,750 (77)	
40		53,600 (34)	53,600 (45)	53,600 (52.5)	53,600 (57)	51,700 (61)	48,200 (64.5)	45,500 (67)	36,850 (69)	39,300 (75)	
45		45,250 (15.5)	45,250 (37)	45,250 (46.5)	45,250 (52.5)	45,250 (57)	42,450 (61)	40,050 (63.5)	32,300 (66)	35,650 (73)	
50			39,000 (25.5)	39,000 (39.5)	39,000 (47)	39,000 (52.5)	37,700 (57)	35,550 (60.5)	28,500 (63)	32,550 (70.5)	
60				27,950 (17.5)	27,950 (34)	27,950 (42.5)	27,950 (48.5)	27,950 (53)	22,600 (56.5)	26,550 (66)	
70						20,250 (29.5)	20,250 (38.5)	20,250 (45)	18,200 (49.5)	21,900 (61.5)	
80							14,850 (25)	14,850 (35)	14,850 (41.5)	18,300 (56.5)	
90								10,850 (20)	10,850 (31.5)	14,100 (51)	
100									7,820 (14.5)	10,800 (45)	
110										8,200 (38.5)	
120										6,070 (30)	
130										4,310 (17.5)	
Minimum boom angle (deg.) for indicated length (no load)									0	0	
Maximum boom length (ft.) at 0 deg. boom angle (no load)									108	140	

Note: Boom angles are in degrees.

A6-829-008234

**CAPACITIES FOR 33 FT. - 58 FT. TELE. OFFSETTABLE EXTENSION  
(ON OUTRIGGERS - 360°)**

Main Boom Angle (Deg.)	33 ft. EXTENSION						48 ft. EXTENSION						58 ft. EXTENSION					
	2° OFFSET		15° OFFSET		30° OFFSET		2° OFFSET		15° OFFSET		30° OFFSET		2° OFFSET		15° OFFSET		30° OFFSET	
	Ref. Rad. (ft.)	Cap. lbs.	Ref. Rad. (ft.)	Cap. lbs.	Ref. Rad. (ft.)	Cap. lbs.	Ref. Rad. (ft.)	Cap. lbs.	Ref. Rad. (ft.)	Cap. lbs.	Ref. Rad. (ft.)	Cap. lbs.	Ref. Rad. (ft.)	Cap. lbs.	Ref. Rad. (ft.)	Cap. lbs.	Ref. Rad. (ft.)	Cap. lbs.
80	29.6	24,000	36.7	19,650	43.1	14,200	33.3	14,800	44.1	12,700	54.2	9,040	35.3	9,600	48.4	8,300	61.6	7,000
75	44.3	20,200	51.0	15,550	57.1	12,200	49.5	13,700	59.7	10,900	69.1	8,320	52.5	9,150	64.9	7,950	77.1	6,440
70	58.7	16,700	64.9	12,400	70.6	10,150	65.2	11,600	74.7	8,840	83.5	7,110	69.4	8,550	80.9	7,200	91.9	5,760
65	72.6	13,000	78.3	10,200	83.6	8,670	80.4	9,230	89.2	7,330	97.2	6,120	85.7	7,630	96.3	6,000	106.1	4,970
60	86.0	10,300	91.1	8,600	95.9	7,510	95.1	7,550	103.0	6,210	110.1	5,340	101.3	6,260	111.0	5,100	119.4	4,360
55	98.6	8,300	103.1	7,380	107.2	6,600	108.9	6,330	116.0	5,360	122.2	4,730	116.1	5,260	124.7	4,410	131.8	3,870
50	110.5	6,800	114.4	6,200	118.2	5,890	122.0	5,410	128.1	4,690	133.4	4,240	130.1	4,490	137.5	3,860	143.2	3,470
45	121.6	5,800	124.7	4,540	128.0	4,380	134.1	3,980	139.2	3,740	143.5	3,580	143.1	3,460	149.3	3,230	153.5	3,070

A6-829-008630

# NOTES FOR LIFTING CAPACITIES

1. All rated loads have been tested to and meet minimum requirements of SAE J1063 OCT80 - Cantilevered Boom Crane Structures - Method of Test, and do not exceed 85% of the tipping load on outriggers (75% of the tipping load on rubber) as determined by SAE J765 OCT80 Crane Stability Test Code.
2. This chart is intended as a guide only. The individual crane's load chart operating instructions and other instruction plates give details of the conditions under which the crane may be operated safely. ALL OF THESE INSTRUCTIONS MUST BE READ AND UNDERSTOOD PRIOR TO OPERATING THE CRANE.
3. Capacities given do not include the weight of hookblocks, slings, auxiliary lifting equipment and load handling devices. Their weights MUST be added to the load to be lifted. When more than minimum required reeving is used, the additional rope weight shall be considered part of the load.
4. Capacities appearing above the bold line are based on structural strength and tipping should not be relied upon as a capacity limitation.
5. All capacities are for crane on firm, level surface. It may be necessary to have structural supports under the outrigger floats or tires to spread the load to a larger bearing surface.
6. When either boom length or radius or both are between values listed, the smallest load shown at either the next larger radius or boom length shall be used.
7. For outrigger operation, ALL outriggers shall be fully extended with tires raised free of ground before raising the boom or lifting loads.
8. Tires shall be inflated to the recommended pressure before lifting on rubber.
9. Unless otherwise stated, capacities are with powered boom sections equally extended.

Constant improvement and engineering progress makes it necessary that we reserve the right to make specification, equipment, and price changes without notice. Illustrations shown may include optional equipment and accessories and may not include all standard equipment.

North and South America, Far East, Australasia

## GROVE MANUFACTURING COMPANY

Box 21 - Shady Grove - Pennsylvania 17256  
(717) 597-8121 - telex: 842308 - fax: (717) 597-4062

Europe, Africa, Middle East, Indian Sub-continent

## GROVE COLES LTD.

Telford Rd. - Bicester - Oxfordshire OX6 0TZ  
(0869) 246800 - telex: 837447 - fax: 0869-246965

FORM NO.: LC-TM1300-Dom.

DATE: 189-10M

PRINTED IN U.S.A.

## 33 FT. FIXED LENGTH EXTENSION (ON OUTRIGGERS - 360°)

Main Boom Angle (Deg.)	2° OFFSET		15° OFFSET		30° OFFSET	
	Rad. Ref. (ft.)	Cap. lbs.	Rad. Ref. (ft.)	Cap. lbs.	Rad. Ref. (ft.)	Cap. lbs.
80	29.6	25,000	36.7	20,200	43.1	14,750
75	44.3	21,000	51.0	16,100	57.1	12,750
70	58.7	17,400	64.9	12,950	70.6	10,700
65	72.6	13,700	78.3	10,750	83.6	9,220
60	86.0	11,000	91.1	9,150	95.9	8,060
55	98.6	9,000	103.1	7,930	107.2	7,150
50	110.5	7,500	114.4	6,750	118.2	6,440
45	121.6	6,500	124.7	5,090	128.0	4,930

A6-829-008635

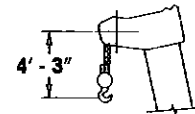

DIMENSIONS ARE FOR LARGEST GROVE FURNISHED HOOK BLOCK AND HEADACHE BALL, WITH ANTI-TWO BLOCK ACTIVATED.

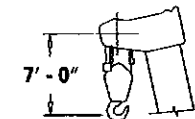

## WEIGHT REDUCTIONS FOR LOAD HANDLING DEVICES

33 FT. FIXED LENGTH EXTENSION	
*Stowed -	935 lbs.
*Erected -	5,722 lbs.

33 FT. - 58 FT. TELE. EXTENSION	
*Stowed -	1,291 lbs.
*Erected (ref.) -	8,416 lbs.
*Erected (ext.) -	11,396 lbs.

\*Reduction of main boom capacities.

HOOKBLOCKS	
130 Ton, 6 Sheave	3,427 lbs.
30 Ton, 1 Sheave	1,022 lbs.
Auxiliary Boom Head	253 lbs.
10 Ton Headache Ball	560 lbs.
15 Ton Headache Ball	803 lbs.





# TM1300

85% Domestic/44 ft.-140 ft. Power Pinned Boom

RANGE DIAGRAM (UNLADEN BOOM)

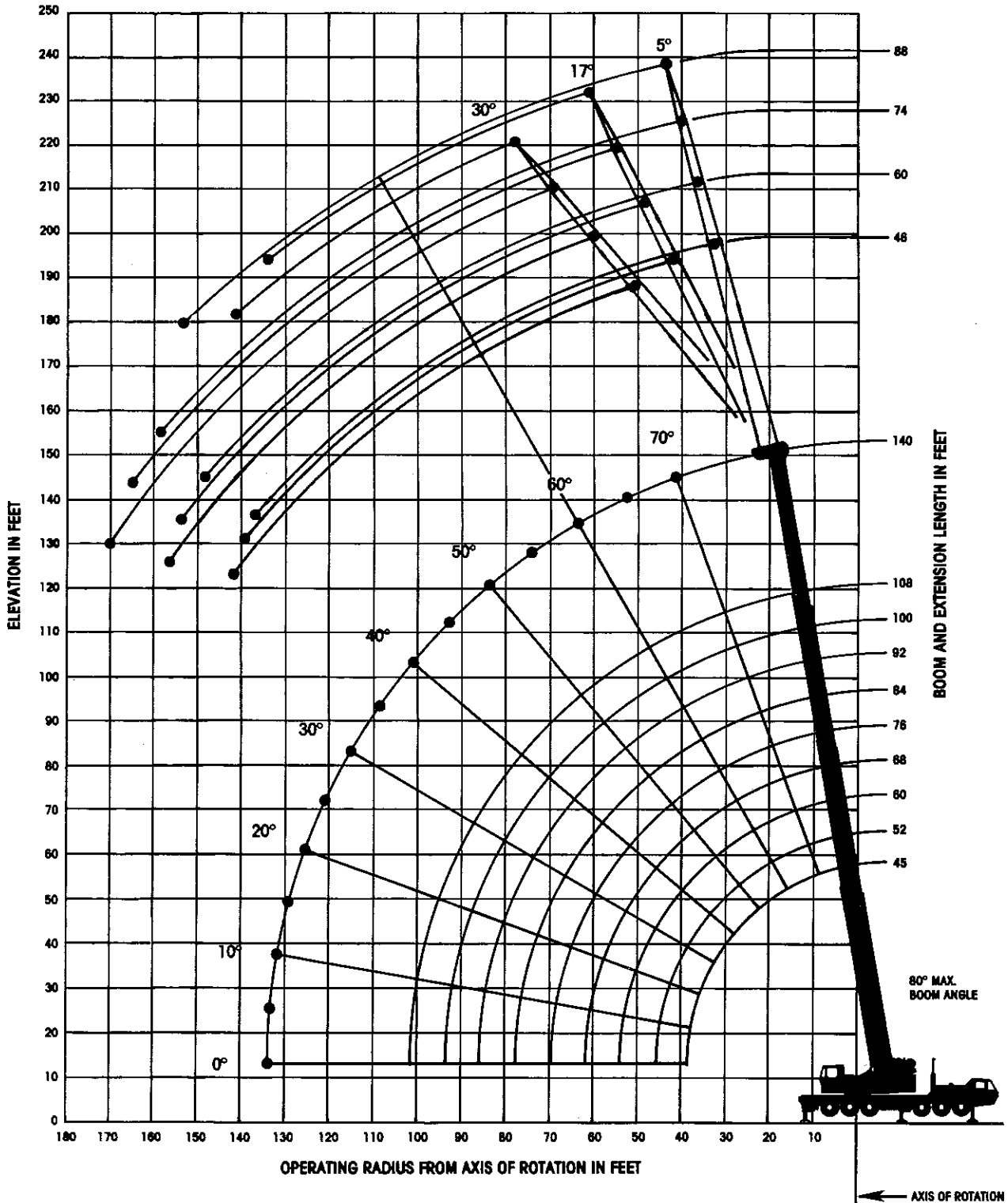

### ON OUTRIGGERS FULLY EXTENDED - 360°

Radius in Feet	Main Boom Length in Feet (Power Pinned Fly Retracted)									Power Pin. Fly Ext. & 108 ft.
	45	52	60	68	76	84	92	100	108	
10	260,000 (75.5)	157,000 (77.5)	155,000 (80)							
12	232,000 (72.5)	157,000 (75.5)	151,500 (78.5)	136,500 (79.5)	130,000 (80)					
15	185,000 (68)	157,000 (72)	137,000 (75)	122,000 (77)	115,000 (78)	107,000 (79.5)				
20	130,500 (60.5)	130,500 (66)	119,000 (70)	104,000 (72.5)	97,100 (74)	89,650 (76)	82,700 (78)	77,400 (79)	66,800 (80)	
25	99,000 (51.5)	99,000 (59.5)	99,000 (64.5)	91,200 (68)	84,000 (70)	77,100 (72.5)	70,800 (74.5)	66,150 (76)	57,500 (77.5)	
30	78,500 (41.5)	78,500 (52.5)	78,500 (58.5)	78,500 (63)	72,050 (66)	67,600 (68.5)	61,850 (71.5)	57,650 (73)	49,350 (75)	45,000 (79.5)
35	64,000 (27.5)	64,000 (44.5)	64,000 (52.5)	64,000 (58)	62,500 (61.5)	59,300 (65)	54,800 (68)	51,000 (70)	42,500 (72)	43,750 (77)
40		53,600 (34)	53,600 (45)	53,600 (52.5)	53,600 (57)	51,700 (61)	48,200 (64.5)	45,500 (67)	36,850 (69)	39,300 (75)
45		45,250 (15.5)	45,250 (37)	45,250 (46.5)	45,250 (52.5)	45,250 (57)	42,450 (61)	40,050 (63.5)	32,300 (66)	35,650 (73)
50			39,000 (25.5)	39,000 (39.5)	39,000 (47)	39,000 (52.5)	37,700 (57)	35,550 (60.5)	28,500 (63)	32,550 (70.5)
60				27,950 (17.5)	27,950 (34)	27,950 (42.5)	27,950 (48.5)	27,950 (53)	22,600 (56.5)	26,550 (66)
70						20,250 (29.5)	20,250 (38.5)	20,250 (45)	18,200 (49.5)	21,900 (61.5)
80							14,850 (25)	14,850 (35)	14,850 (41.5)	18,300 (56.5)
90								10,850 (20)	10,850 (31.5)	14,100 (51)
100									7,820 (14.5)	10,800 (45)
110										8,200 (38.5)
120										6,070 (30)
130										4,310 (17.5)
Minimum boom angle (deg.) for indicated length (no load)									0	0
Maximum boom length (ft.) at 0 deg. boom angle (no load)									108	140

Note: Boom angles are in degrees.

A6-829-009234

### CAPACITIES FOR 46 FT. - 88 FT. FIXED OFFSET JIB (ON OUTRIGGERS - 360°)

Loaded Main Boom Angle	46 ft. JIB						60 ft. JIB						74 ft. JIB						88 ft. JIB		
	5° OFFSET		17° OFFSET		30° OFFSET		5° OFFSET		17° OFFSET		30° OFFSET		5° OFFSET		17° OFFSET		30° OFFSET		5° OFFSET	17° C	
	Ref. Rad.*	Load lbs.**	Ref. Rad.	Load lbs.	Ref. Rad.	Load lbs.	Ref. Rad.	Load lbs.	Ref. Rad.	Load lbs.	Ref. Rad.	Load lbs.	Ref. Rad.	Load lbs.	Ref. Rad.	Load lbs.	Ref. Rad.	Load lbs.	Ref. Rad.	Load lbs.	
80°	36.6	16,200	45.8	12,500	54.5	8,160	44.9	12,150	54.1	8,900	63.3	3,250	46.0	9,260	59.5	6,300	72.0	3,500	47.8	7,280	65.0
77.5	44.8	15,350	53.6	12,000	62.0	7,730	53.3	11,350	62.4	8,470	71.2	4,950	55.1	8,540	68.3	5,890	80.4	3,270	57.5	6,570	74.3
75	52.8	14,600	61.2	11,600	69.3	7,350	61.7	10,700	70.6	8,070	78.9	4,690	64.1	7,910	77.0	5,520	88.7	3,060	67.1	5,940	83.5
72.5	60.8	13,950	68.2	11,200	76.5	7,020	69.9	10,100	78.6	7,610	86.6	4,460	73.0	7,350	85.6	5,190	96.8	2,890	76.6	5,390	92.6
70	68.7	12,300	76.2	10,700	83.5	6,730	77.9	9,570	86.5	7,120	94.0	4,250	81.7	6,840	94.0	4,890	104.7	2,730	85.9	4,890	101.4
67.5	76.4	11,350	83.4	8,820	90.4	6,480	85.9	8,420	94.2	6,690	101.3	4,070	90.3	6,380	102.2	4,580	112.4	2,590	95.0	4,440	110.1
65	84.0	10,950	90.5	8,380	97.1	6,250	93.6	7,260	101.8	6,030	108.3	3,920	98.7	5,800	110.2	4,290	119.9	2,470	104.0	4,040	118.5
62.5	91.4	9,200	97.4	8,030	103.6	5,680	101.2	6,920	109.1	5,270	115.2	3,780	107.0	4,680	118.0	4,050	127.2	2,360	112.8	3,680	126.8
60	98.7	7,730	104.1	6,540	109.9	5,360	108.7	6,200	116.3	5,050	121.8	3,660	115.0	3,980	125.5	2,960	134.2	1,990	121.3	3,180	134.7
55	112.6	5,300	117.0	5,220	121.9	5,150	122.9	4,760	129.9	3,960	134.4	3,170	122.8	3,460	140.0	2,530	147.5	1,870	137.7	1,420	
50	125.7	3,700	128.9	3,600	132.9	3,500	136.2	3,400	142.6	3,050	145.9	2,700	144.9	2,560	153.3	2,180	159.6	1,800	153.1	1,020	
45	137.8	2,860	139.9	2,760	142.9	2,600	148.5	2,160	154.1	2,080	156.4	2,000	158.2	1,720	165.5	1,710	170.5	1,700			

\* Ref. radius (ft.) refers to fully extended boom and appropriate jib length

\*\* Capacities at loaded main boom angle

### 33 FT. FIXED LENGTH EXTENSION (ON OUTRIGGERS - 360°)

Main Boom Angle (Deg.)	2° OFFSET		15° OFFSET		30° OFFSET	
	Rad. Ref. (ft.)	Cap. lbs.	Rad. Ref. (ft.)	Cap. lbs.	Rad. Ref. (ft.)	Cap. lbs.
80	29.6	25,000	36.7	20,200	43.1	14,750
75	44.3	21,000	51.0	16,100	57.1	12,750
70	58.7	17,400	64.9	12,950	70.6	10,700
65	72.6	13,700	78.3	10,750	83.6	9,220
60	86.0	11,000	91.1	9,150	95.9	8,060
55	98.6	9,000	103.1	7,930	107.2	7,150
50	110.5	7,500	114.4	6,750	118.2	6,440
45	121.6	6,500	124.7	5,090	128.0	4,930

A6-829-008635

### WEIGHT REDUCTIONS FOR LOAD HANDLING DEVICES

45 FT. - 140 FT. BOOM WITH	
*46 ft. Jlb Erected -	9,608 lbs.
*60 ft. Jlb Erected -	14,558 lbs.
*74 ft. Jlb Erected -	20,422 lbs.
*88 ft. Jlb Erected -	27,168 lbs.
*33 ft. Extension (Stowed) -	935 lbs.
*33-58 ft. Extension Stowed -	1,291 lbs.
Fixed Jlb Accessories -	327 lbs.

\*Reduction of main boom capacities.

HOOKBLOCKS	
130 Ton, 6 Sheave .....	3,427 lbs.
30 Ton, 1 Sheave .....	1,022 lbs.
Auxiliary Boom Head .....	253 lbs.
10 Ton Headache Ball .....	560 lbs.
15 Ton Headache Ball .....	803 lbs.

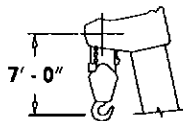
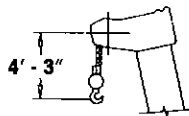

DIMENSIONS ARE FOR LARGEST GROVE FURNISHED HOOK BLOCK AND HEADACHE BALL, WITH ANTI-TWO BLOCK ACTIVATED.

## NOTES FOR LIFTING CAPACITIES

- All rated loads have been tested to and meet minimum requirements of SAE J1063 OCT80 - Cantilevered Boom Crane Structures - Method of Test, and do not exceed 85% of the tipping load on outriggers (75% of the tipping load on rubber) as determined by SAE J765 OCT80 Crane Stability Test Code.
- This chart is intended as a guide only. The individual crane's load chart operating instructions and other instruction plates give details of the conditions under which the crane may be operated safely. ALL OF THESE INSTRUCTIONS MUST BE READ AND UNDERSTOOD PRIOR TO OPERATING THE CRANE.
- Capacities given do not include the weight of hookblocks, slings, auxiliary lifting equipment and load handling devices. Their weights MUST be added to the load to be lifted. When more than minimum required reeving is used, the additional rope weight shall be considered part of the load.
- Capacities appearing above the bold line are based on structural strength and tipping should not be relied upon as a capacity limitation.
- All capacities are for crane on firm, level surface. It may be necessary to have structural supports under the outrigger floats or tires to spread the load to a larger bearing surface.
- When either boom length or radius or both are between values listed, the smallest load shown at either the next larger radius or boom length shall be used.
- For outrigger operation, ALL outriggers shall be fully extended with tires raised free of ground before raising the boom or lifting loads.
- Tires shall be inflated to the recommended pressure before lifting on rubber.
- Unless otherwise stated, capacities are with powered boom sections equally extended.

IB		
FFSET	30° OFFSET	
Load lbs.	Ref. Rad.	Load lbs.
4,330	83.2	2,330
3,940	92.2	2,130
3,580	100.9	1,960
3,260	109.4	1,810
2,970	117.7	1,680
2,710	125.9	1,560
2,470	133.7	1,460
2,260	141.3	1,050
1,450		

A6-829-008343

Constant improvement and engineering progress makes it necessary that we reserve the right to make specification, equipment, and price changes without notice. Illustrations shown may include optional equipment and accessories and may not include all standard equipment.

North and South America, Far East, Australasia

### GROVE MANUFACTURING COMPANY

Box 21 ■ Shady Grove ■ Pennsylvania 17256

(717) 597-8121 ■ telex: 842308 ■ fax: (717) 597-4062

Europe, Africa, Middle East, Indian Sub-continent

### GROVE COLES LTD.

Telford Rd. ■ Blcester ■ Oxfordshire OX6 0TZ

(0869) 246800 ■ telex: 837447 ■ fax: 0869-246965

FORM NO.: LC-TM1300-Dom.

DATE: 189-10M ; PRINTED IN U.S.A.